

CH WORM GEARED MOTORS AND WORM GEAR UNITS



INTRODUCTION

The new CH worm gearboxes of Chiaravalli Group S.p.A. have been produced to satisfy the market that require a product in dimensions and construction without changing the existing drawings and to guarantee non stop of their spare parts.

Chiaravalli Group S.p.A. designed this new product by improving and introducing better technical modifications to offer easier application of the groups to the different assembling configurations so that by offering a better service in flexibility and delivery time.

Starting from these considerations, we have a gearbox with a motor mounting flange that is separable from the housing which incorporate the oil seal; in this way we avoid any risk of damaging the oil seal in case of replacement of the input flange and the O-Ring can be eliminated.

All the aside covers, swinging and with feet, have O-Rings instead of traditional flat gaskets. The sizes 03-04-05 allow the rotation of the feet without disassembling them; furthermore the versions with swinging aside covers allow the lateral flanges to be fitted on both sides with simple fixing screws.

The worm screw has a ZI involute profile: with this worm-wheel coupling we shall get a better performance with a temperature reduction.

The gearboxes and motors are painted with RAL 9022 aluminium colour epoxy powder to protect the parts from oxidation and against micro-blowholes that can come during the pressure of die-castings.

The CHPC pre-stage gears (already present in the catalogue of CHM) can also be mounted with this range, obtaining a gear ratio up to 1:300.

For bigger reductions is possible to have two gears together using an appropriate kit.



LUBRICATION

All of the groups are supplied with a synthetic lubricant maintenance free and can be mounted in any position. The types of lubricants are described in the table here below.

Lubricant	Ambient	ISO	AGIP	SHELL	IP
°C ambient	-25°C/+50°C	VG 320	Telium VSF 320	Tivela oil S 320	Telium VSF



QUANTITY OF OIL IN LITRES

CH	03	04	05	06	07	08
	0.035	0.055	0.090	0.38	0.52	0.73



MOTOR MOUNTING FLANGES

Gears supplied with mounting flanges must be assembled with motors whose shaft and flange tolerances correspond to a "normal" class of quality in order to avoid vibration and forcing of the input bearing. Motors supplied by Chiaravalli Group S.p.A. guarantee this requirement fulfilled. For ease of consultation, the correspondence of the size of the B5 and B14 motor with the sizes of the shaft and the motor connection flange are shown in the following table.

Remember that, as the motor connection flanges are separate from the body it is also possible to have a shaft / flange combination that does not correspond to the table, e.g. 19/140, thereby offering adaptability for other non-unified models such as the brushless or direct current types.

MMF	056	063	071	080	090	100	112
B5	9/120	11/140	14/160	19/200	24/200	28/250	28/250
B14	9/80	11/90	14/105	19/120	24/140	28/160	28/160



FEET ROTATION

Gears with feet can be rotated into the N and V positions by simply unscrewing the fixing screws. We recommend that some sealant is applied to the 4 screws close to the worm screw, as the holes are through holes.



CH...



CH...P



CHE...P

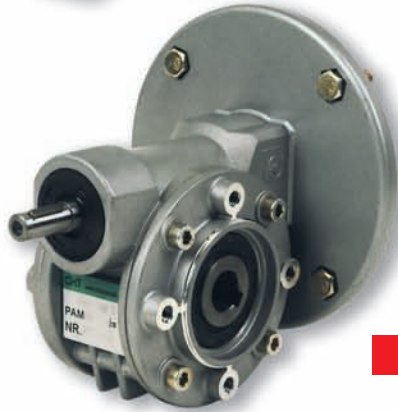

CHE...

CHR...



CHR...P



CHRE...



CHRE...P





CH - CH...P 03/04/05 DESIGNATION

TYPE (1)	SIZE	VERSION	FLANGE POS. (2)	i	M.M.F.	MOUNT. POS.
CH	03	A	1	RATIO SEE PAGE 64	63B5	UNIVERSALE
CH..P		P	2		63B14	
CHR		PF			56B5	
CHR..P		N			56B14	
CHE		V				
CHE..P						
CHRE						
CHRE..P						

TYPE (1)	SIZE	VERSION	FLANGE POS. (2)	i	M.M.F.	MOUNT. POS.
CH	04	A	1	RATIO SEE PAGE 65	71B5	UNIVERSALE
CH..P		P	2		71B14	
CHR		PF			63B5	
CHR..P		PFA			63B14	
CHE		N				
CHE..P		V				
CHRE						
CHRE..P						

TYPE (1)	SIZE	VERSION	FLANGE POS. (2)	i	M.M.F.	MOUNT. POS.
CH	05	A	1	RATIO SEE PAGE 66	80B5	UNIVERSALE
CH..P		P	2		80B14	
CHR		PF			71B5	
CHR..P		PFA			71B14	
CHE		N			63B5	
CHE..P		V			63B14	
CHRE						
CHRE..P						



ORDER EXAMPLE

CH	04P	FA	2	35	63 B14
CH	04			10	71 B5

If the motor is also required, please specify:

Size es. 63 C4
 Power es. Kw 0.22
 Poles es. 4
 Voltage es. V230/400
 Frequency es. 50 Hz
 Flange es. B14

N.B. Gear box required with output flanges F or FA must be ordered PF or PFA version.

1) see page 61
 2) see page 63

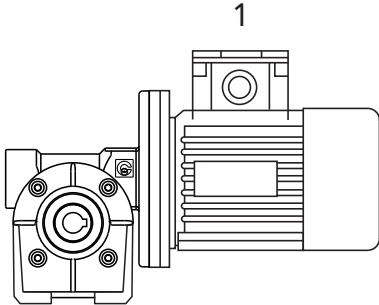
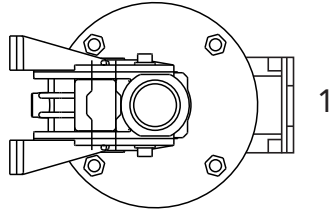
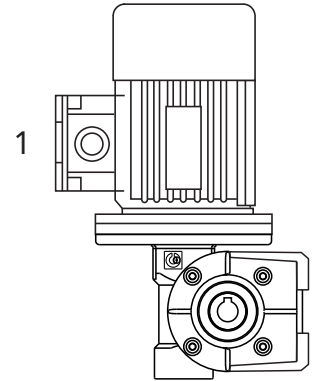
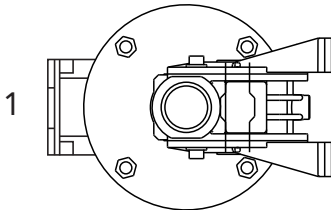
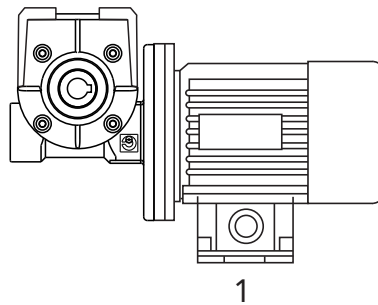
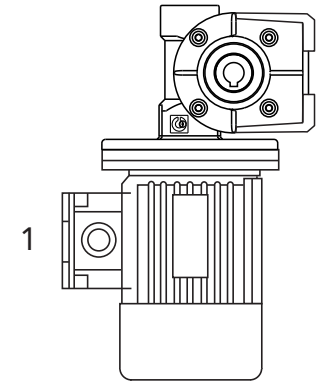
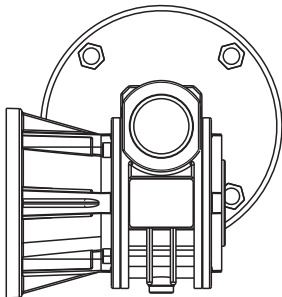
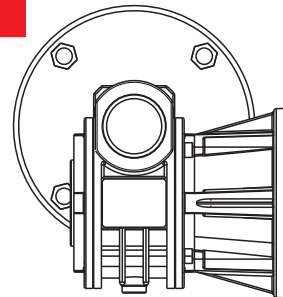
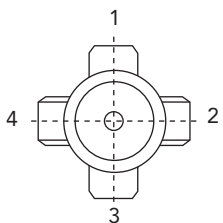
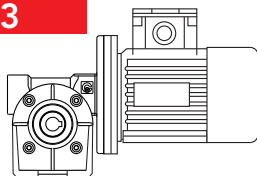
**B3****B6****V5****B7****B8****V6****PF1****PF2****B3****TERMINAL BOX POSITION**

N.B. The position of the terminal box always refers to the B3 position.



CH 03 - PERFORMANCE WITH 4-POLE MOTORS 1400 REVS. INPUT

TYPE	i=ratio	n2 r/min	Kw=P1	Nm=T2	f.s.	Possible types of motor connections	
CH 03	7	200	0.22	8	1.8	63/56	B5/B14
	10	140	0.22	11	1.4	63/56	B5/B14
	15	93	0.22	16	1.0	63/56	B5/B14
	20	70	0.22	20	0.9	63/56	B5/B14
	30	47	0.18	22	0.8	63/56	B5/B14
	40	35	0.12	18	1.0	63/56	B5/B14
	60	23	0.09	18	1.0	63/56	B5/B14
	70	20	0.09	15	0.9	56	B5/B14

Weight Kg 1

DIMENSIONS

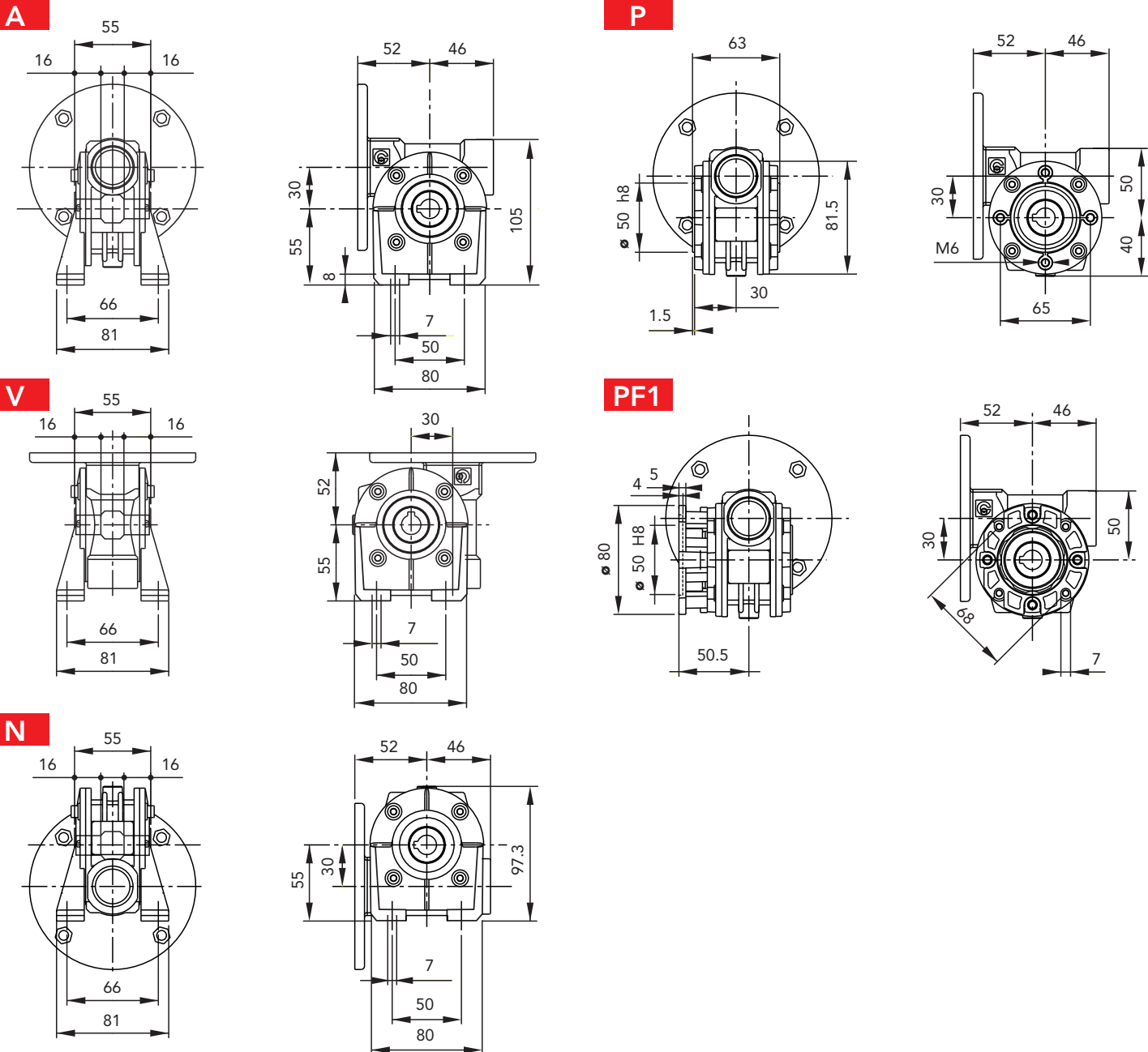



CH 04 - PERFORMANCE WITH 4-POLE MOTORS 1400 REVS. INPUT

TYPE	i=ratio	n2 r/min	Kw=P1	Nm=T2	f.s.	Possible types of motor connections	
	7	200	0.55*	22	1.4	71/63	B5/B14
	10	140	0.55*	30	1.0	71/63	B5/B14
	14	100	0.37	29	1.0	71/63	B5/B14
	20	70	0.37	38	1.0	71/63	B5/B14
	28	50	0.37	40	0.9	71/63	B5/B14
	35	40	0.25	41	0.9	71/63	B5/B14
	46	30	0.18	37	1.0	63	B5/B14
	60	23	0.18	37	0.9	63	B5/B14
	70	20	0.12	33	0.9	63	B5/B14
	100	14	0.12	30	0.9	63	B5/B14

CH 04

* Motors 71 gr.

Weight Kg 2,1

DIMENSIONS

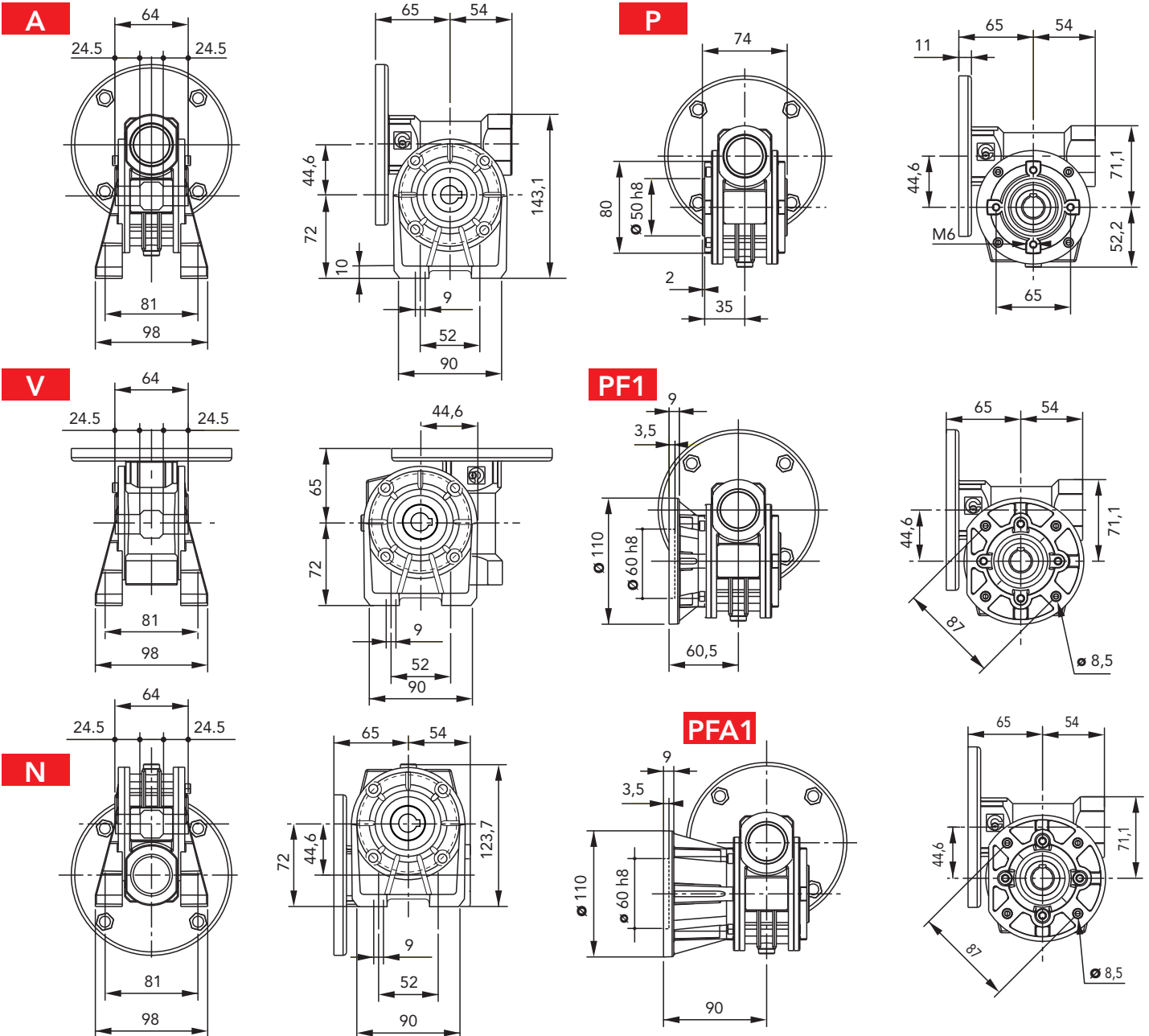



CH 05 - PERFORMANCE WITH 4-POLE MOTORS 1400 REVS. INPUT

TYPE	i=ratio	n2 r/min	Kw=P1	Nm=T2	f.s.	Possible types of motor connections	
CH 05	7	200	1.1*	40	1.4	80/71	B5/B14
	10	140	1.1*	49	1.2	80/71	B5/B14
	14	100	0.75	57	1.1	80/71	B5/B14
	18	78	0.55	52	1.1	80/71	B5/B14
	24	58	0.55	67	0.9	80/71	B5/B14
	28	50	0.55	73	1.0	80/71	B5/B14
	36	39	0.37	61	1.1	71	B5/B14
	45	31	0.37	65	0.9	71	B5/B14
	60	23	0.25	60	1.0	71/63	B5/B14
	70	20	0.22	55	0.9	63	B5/B14
	80	17	0.18	54	1.0	63	B5/B14
	100	14	0.18	50	0.9	63	B5/B14

* Motors 80 gr.

Weight Kg 3

DIMENSIONS

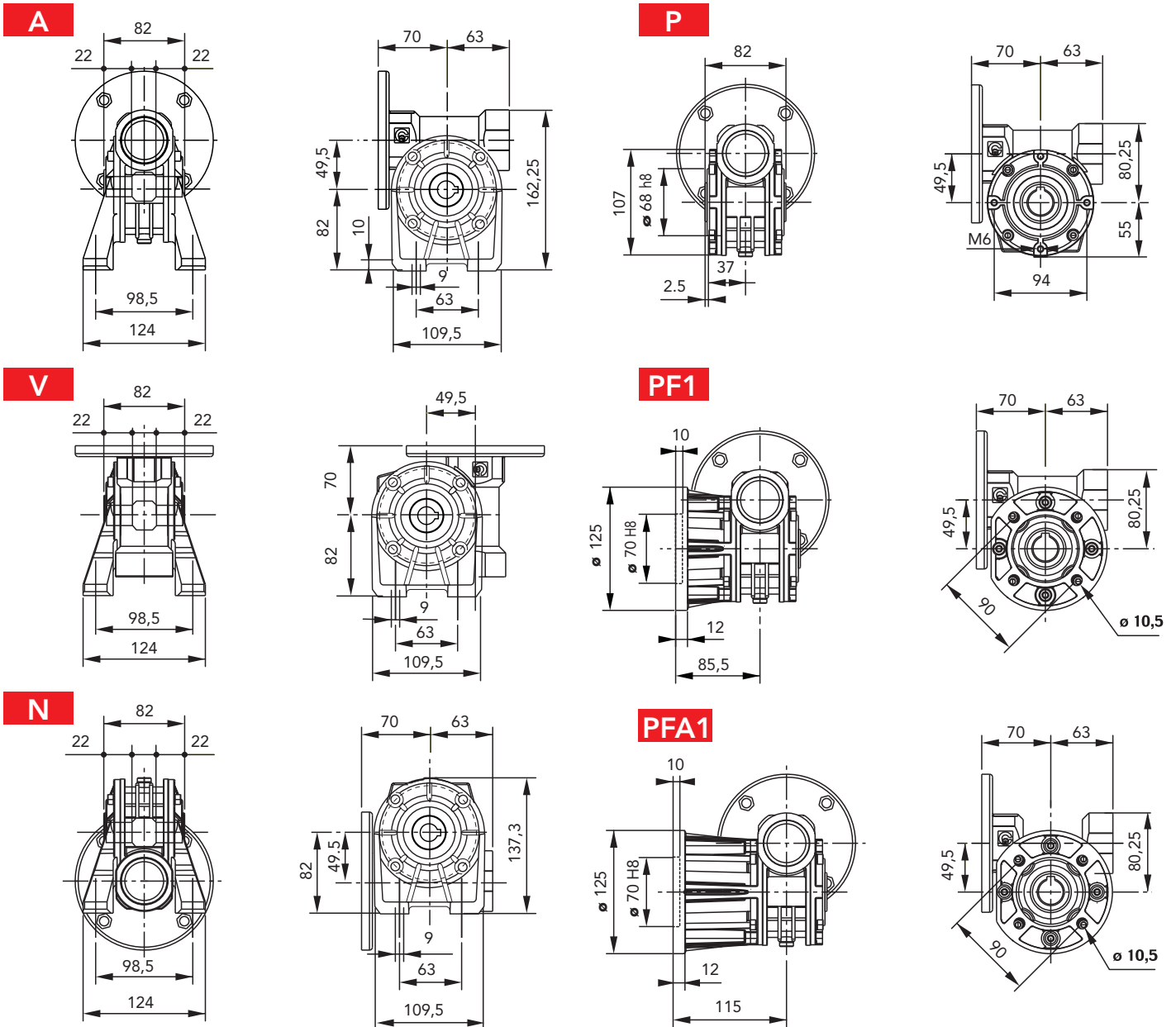

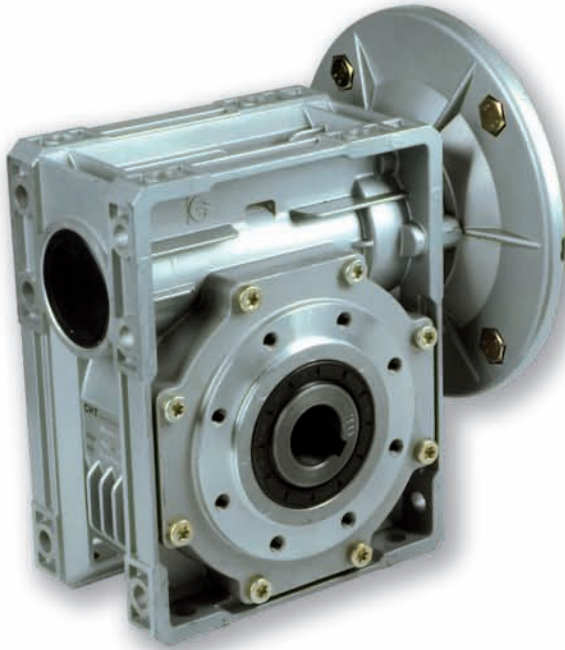

CH..

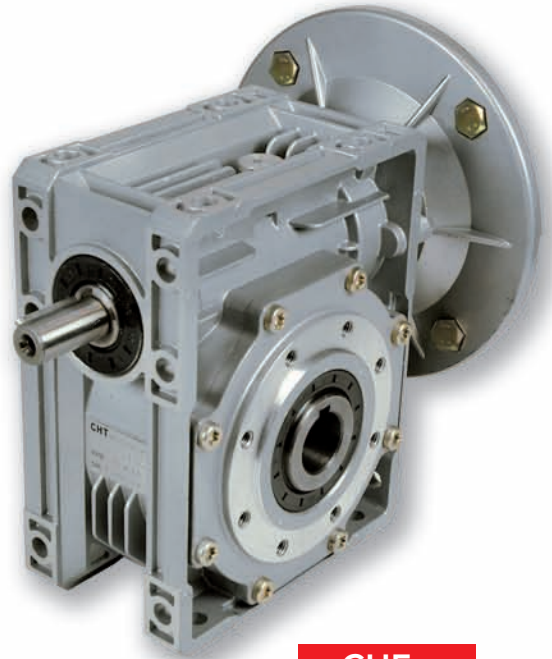

CHE..

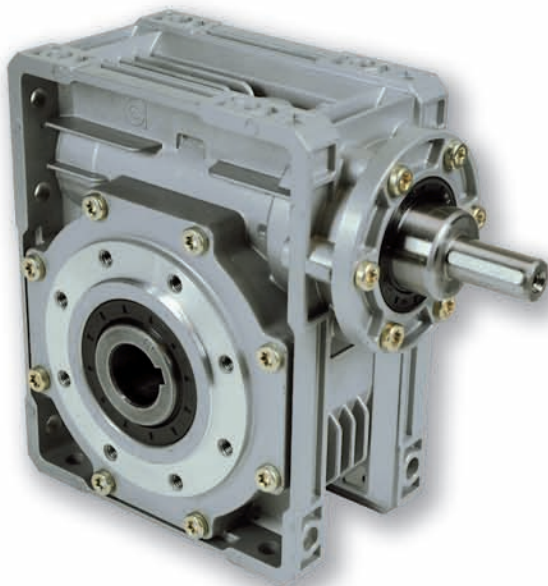

CHR..

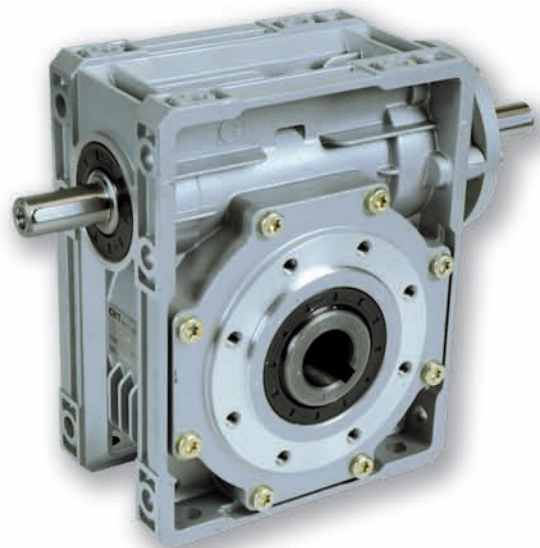

CHRE..



CH 06/07/08 DESIGNATION

TYPE (1)	SIZE	VERSION	FLANGE POS. (2)	i	M.M.F.	MOUNT. POS.
CH	06	FC	1	RATIO SEE PAGE 70-71-72	100B5	UNIVERSALE
CHR	07	F	2		100B14	
CHE	08	(3)			90B5	
CHRE					90B14	
					80B5	
				80B14		
				71B5		
				71B14		



ORDER EXAMPLE

CH	06	FC	1	19	90 B5
----	----	----	---	----	-------

If the motor is also required, please specify:

Size es. 90 L4
Power es. Kw 1.5
Poles es. 4
Voltage es. V230/400
Frequency es. 50 Hz
Flange es. B5

1) see page 67

2) see page 69

3) lack of instructions indicates that the gear is not equipped with an output flange



MOUNTING POSITION

B3

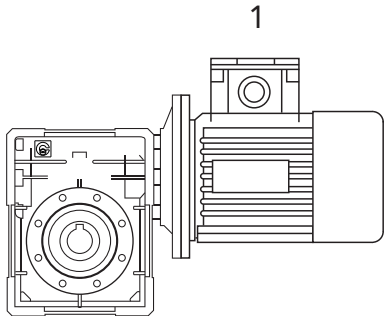

B6

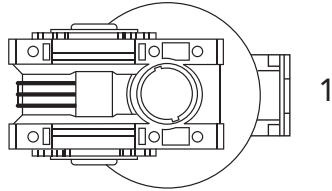

V5

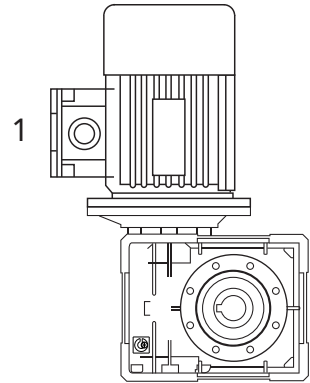

B7

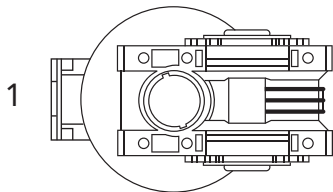

B8

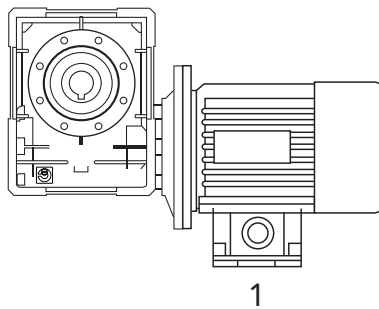

V6

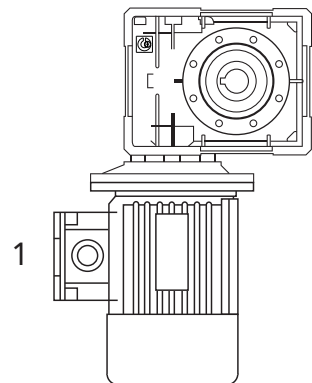

F1

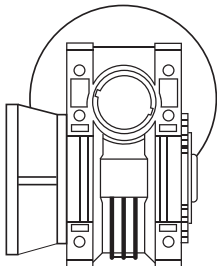

F2

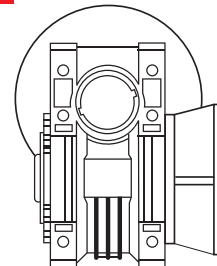

B3

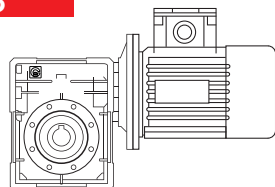
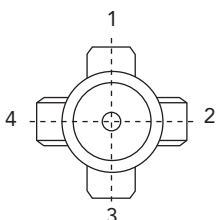

TERMINAL BOX POSITION

N.B. The position of the terminal box always refers to the B3 position.



CH 06 - PERFORMANCE WITH 4-POLE MOTORS 1400 REVS. INPUT

TYPE	i=ratio	n2 r/min	Kw=P1	Nm=T2	f.s.	Possible types of motor connections	
CH 06	7	200	1.85	75	1.5	90/80	B5/B14
	10	140	1.85	105	1.3	90/80	B5/B14
	12	117	1.85	129	1.1	90/80	B5/B14
	15	93	1.85	146	1.0	90/80	B5/B14
	19	74	1.50	150	1.0	90/80	B5/B14
	24	58	1.10	138	1.1	90/80	B5/B14
	30	47	1.10	155	1.0	90/80	B5/B14
	38	37	0.75	133	1.1	90/80	B5/B14
	45	31	0.75	152	0.9	80/71	B5/B14
	64	22	0.37	101	1.2	80/71	B5/B14
	80	17	0.37	112	1.0	71	B5/B14
	100	14	0.37	110	1.0	71	B5/B14

Weight Kg 5,2

DIMENSIONS

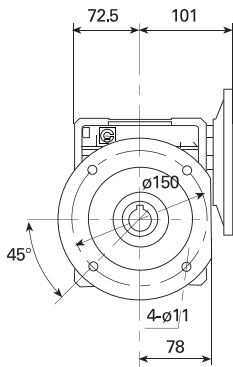
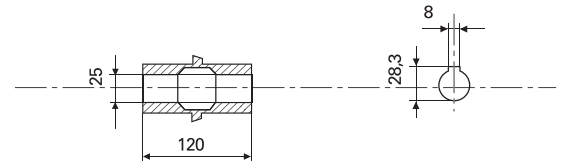
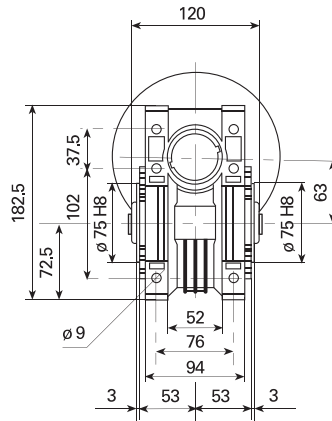
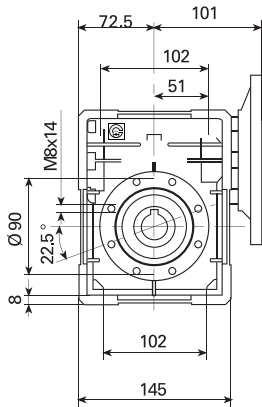

CH06FC 1

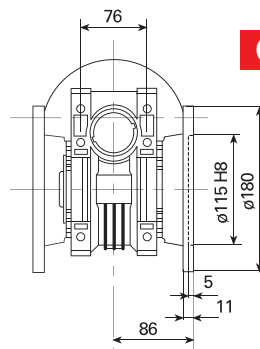

CH06FC 2

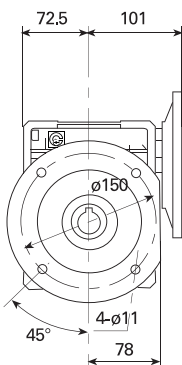

CH06F1

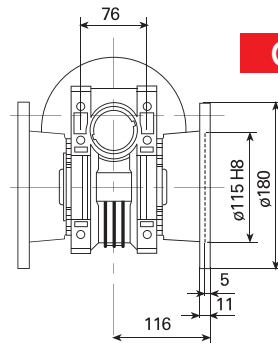

CH06F2



CH 07 - PERFORMANCE WITH 4-POLE MOTORS 1400 REVS. INPUT

TYPE	i=ratio	n2 r/min	Kw=P1	Nm=T2	f.s.	Possible types of motor connections
CH 07	7	200	4	170	1.1	100/90 B5/B14
	10	140	3	175	1.3	100/90 B5/B14
	15	93	3	250	1.0	100/90 B5/B14
	20	70	2.20	240	1.0	100/90 B5/B14
	25	56	1.85	250	1.0	90/80 B5/B14
	30	47	1.50	230	1.2	90/80 B5/B14
	40	35	1.1	215	1.2	90/80 B5/B14
	50	28	1.1	220	0.9	90/80 B5/B14
	60	23	0.75	200	1.0	90/80 B5/B14
	80	17	0.55	180	1.0	80/71 B5/B14 *
100	14	0.37	140	1.1	80/71 B5/B14 *	

*71 solo B5

Weight Kg 9,2

DIMENSIONS

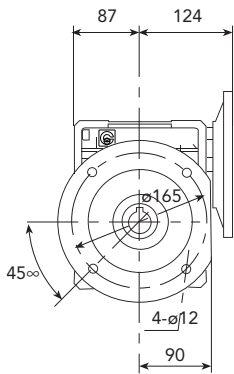
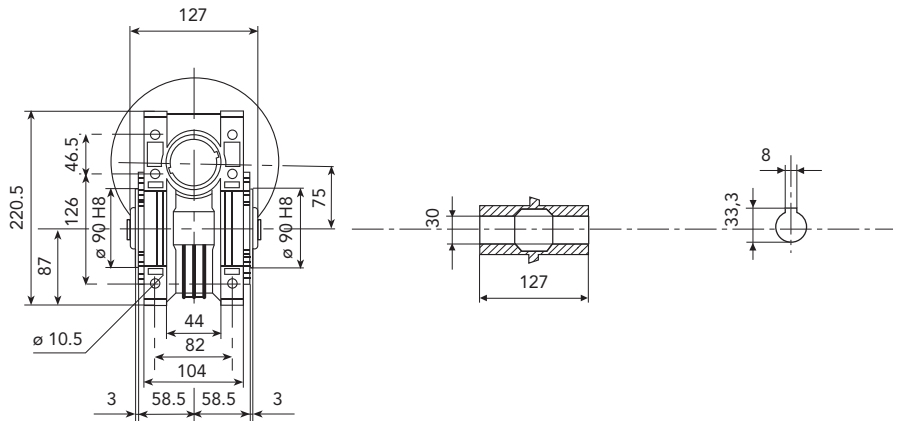
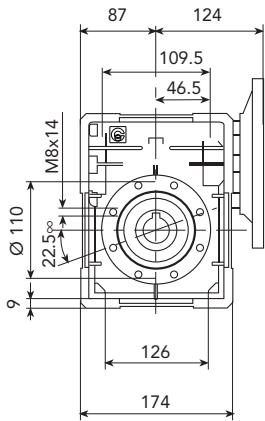

CH07FC 1

CH07FC 2

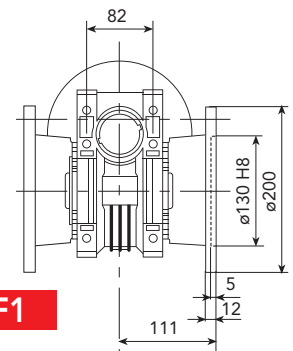
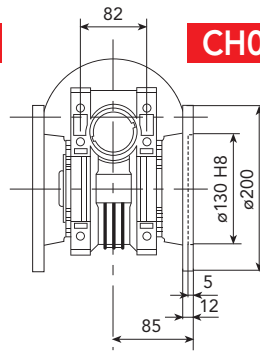

CH07F1

CH07F2

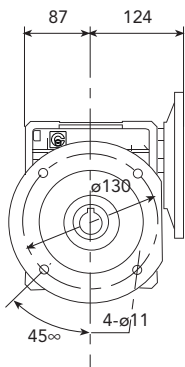

CH07FE1

CH07FE2

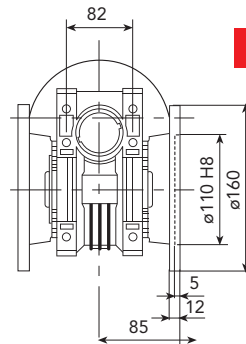



CH 08 - PERFORMANCE WITH 4-POLE MOTORS 1400 REVS. INPUT

TYPE	i=ratio	n2 r/min	Kw=P1	Nm=T2	f.s.	Possible types of motor connections	
CH 08	7	200	4	170	1.5	112/100/90	B5/B14
	10	140	4	240	1.2	112/100/90	B5/B14
	15	93	4	350	0.9	112/100/90	B5/B14
	20	70	3.00	340	0.9	100/90	B5/B14
	23	61	2.20	280	1.1	100/90	B5/B14
	30	47	2.20	340	1.1	100/90	B5/B14
	40	35	1.85	340	0.9	90/80	B5/B14
	46	30	1.5	340	1.0	90/80	B5/B14
	56	25	1.1	290	1.0	90/80	B5/B14
	64	22	1.1	290	0.9	90/80	B5/B14
	80	17	0.75	260	1.0	90/80	B5/B14
	100	14	0.55	220	1.0	80	B5/B14

Weight Kg 12,2

DIMENSIONS

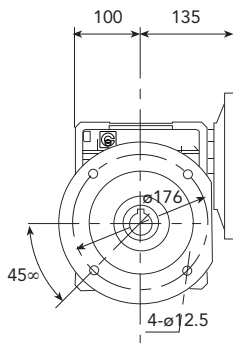
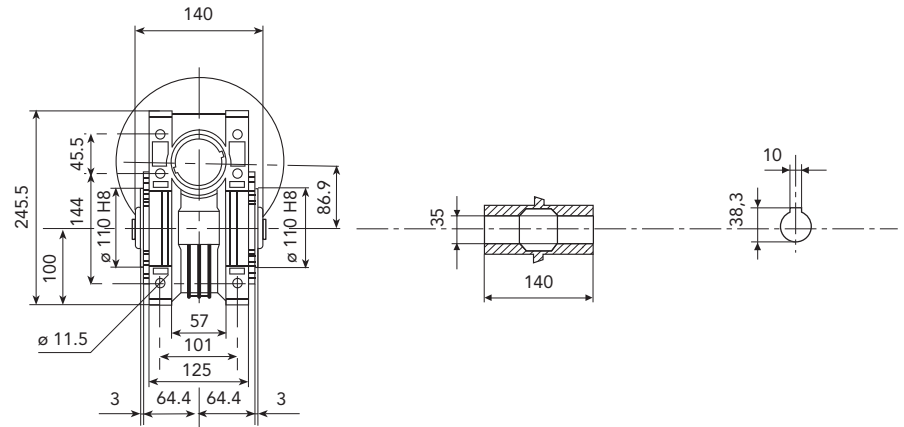
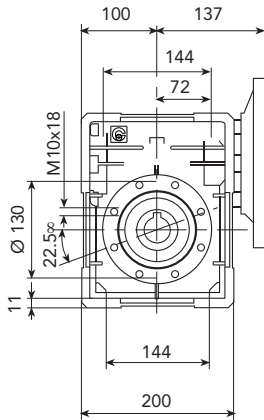

CH08FC 1

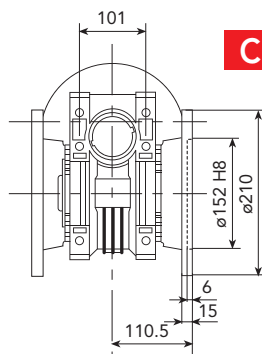

CH08FC 2

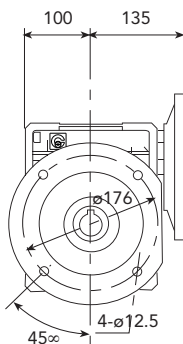

CH08F1

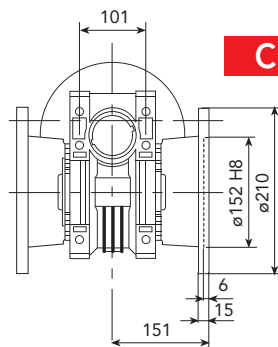

CH08F2



CHR 03-04-05

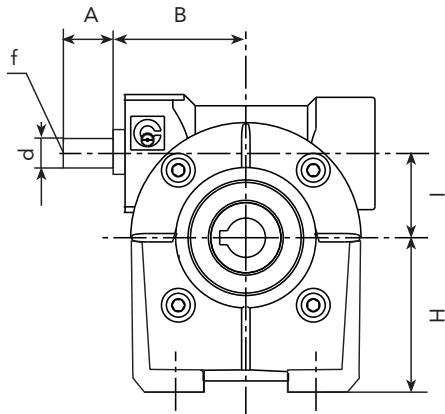

CHR 06-07-08

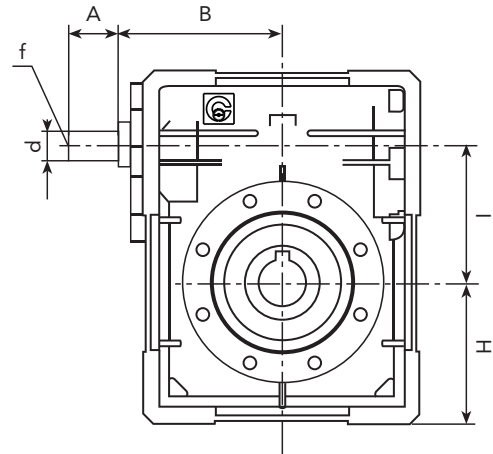

CHRE 03-04-05

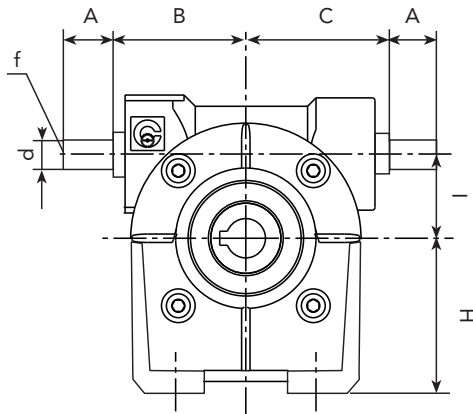

CHRE 06-07-08

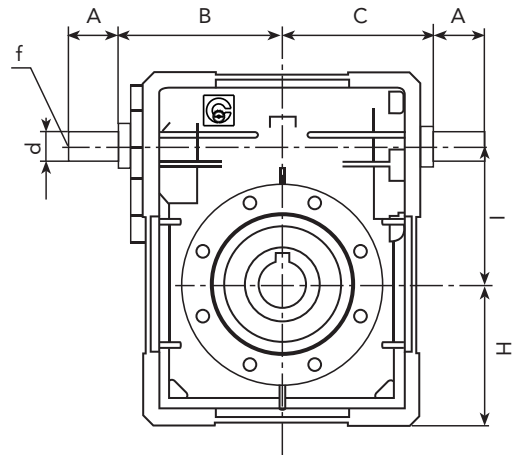

OUTPUT SHAFT DIMENSIONS

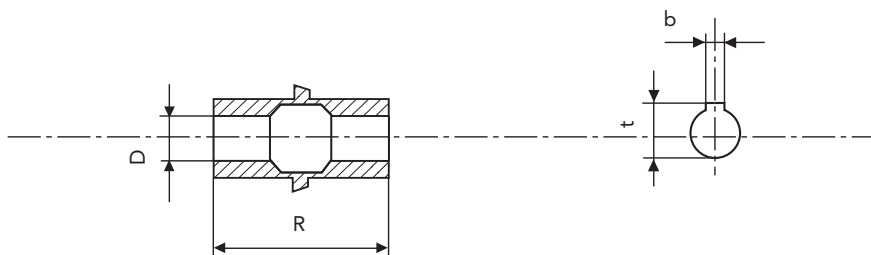

TYPE	A	B	C	D(H7)	d(h6)	f	H	I	R	b	t
CHR 03	20	50	/	14	9	/	55	30	55	5	16.3
CHR 04	30	54	/	18	11	/	72	44.6	64	6	20.8
CHR 05	40	65	/	25	16	M6	82	49.5	82	8	28.3
CHR 06	40	110.5	/	25	18	M6	72.5	62.17	120	8	28.3
CHR 07	40	128	/	30	19	M6	87	75	127	8	33.3
CHR 08	50	144	/	35	25	M8	100	86.9	140	10	38.8
CHRE 03	20	50	50	14	9	/	55	30	55	5	16.3
CHRE 04	30	54	56	18	11	/	72	44.6	64	6	20.8
CHRE 05	40	65	65	25	16	M6	82	49.5	82	8	28.3
CHRE 06	40	110.5	74	25	18	M6	72.5	62.17	120	8	28.3
CHRE 07	40	128	88.5	30	19	M6	87	75	127	8	33.3
CHRE 08	50	144	101.5	35	25	M8	100	86.9	140	10	38.3



CHPC/CH - WORM GEAR WITH PRE-STAGE MODULE

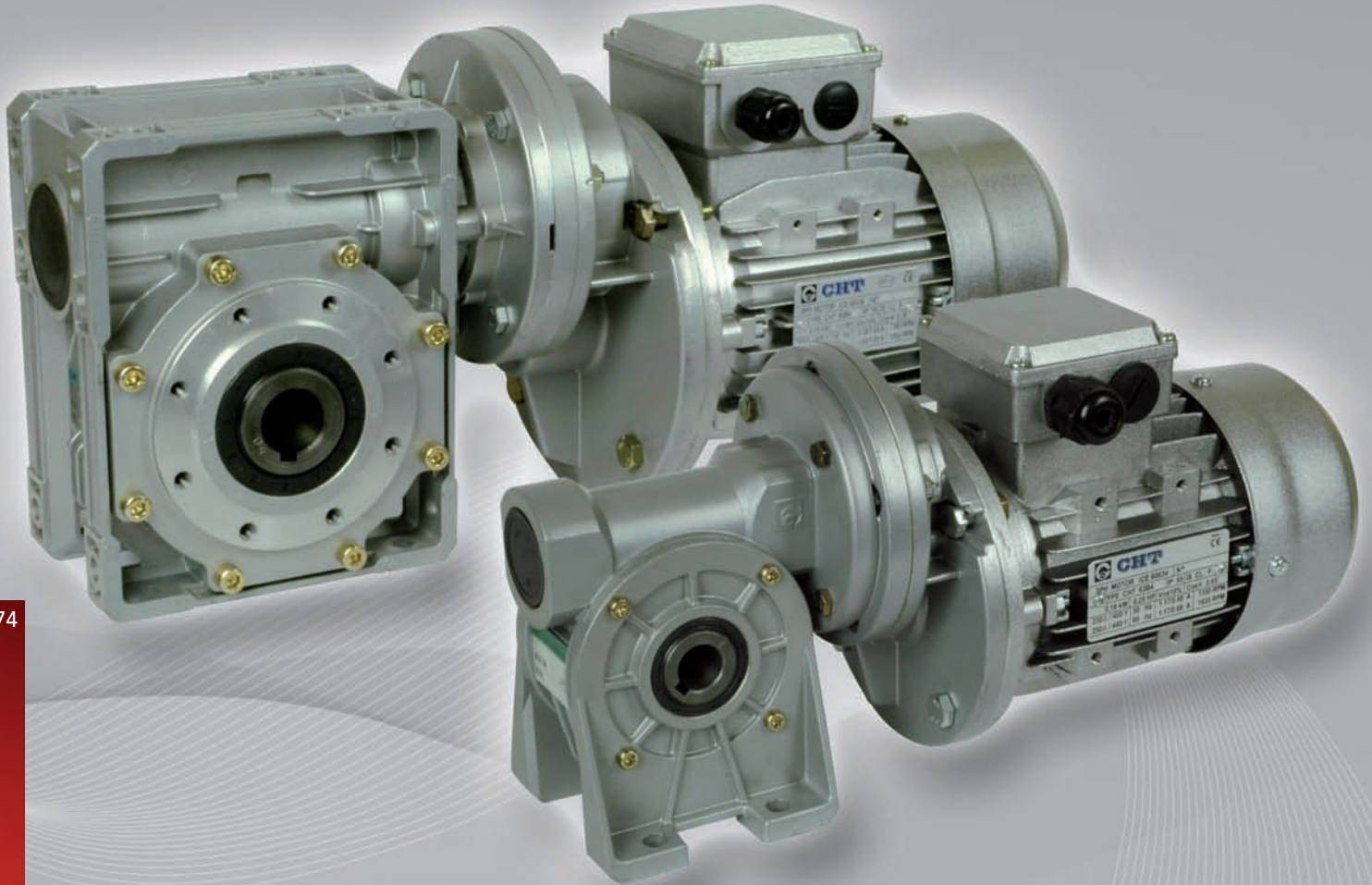



WORM GEAR WITH PRE-STAGE MODULE

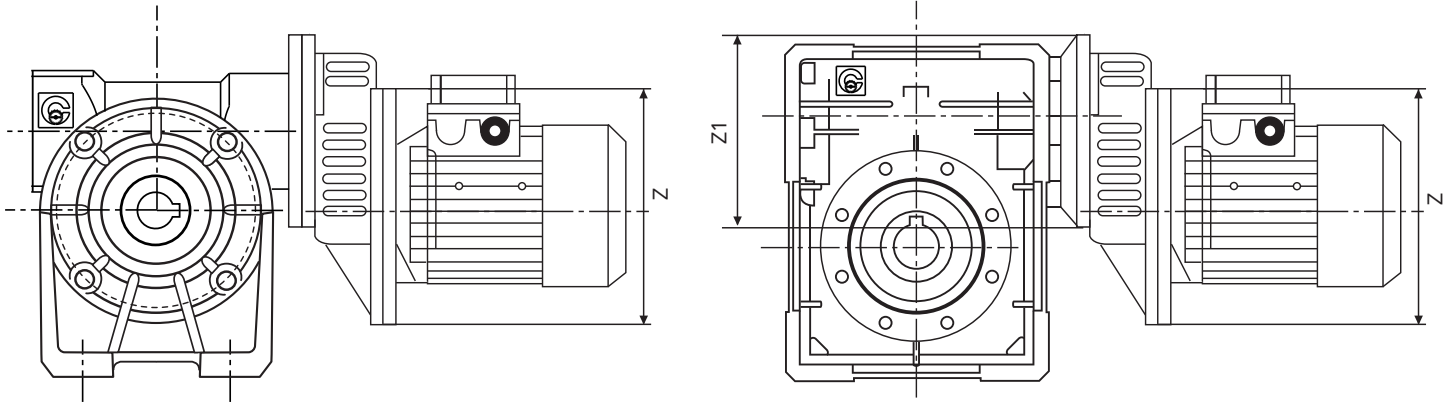

	Z	Z1
CHPC 63	11/140	11/105
CHPC 71	14/160	14/120
CHPC 80	19/200	19/160

WARNING: The gearbox connected with the pre-stage must have input dimension Z1

DESIGNATION	CHPC / CH - CH..P	CHPC / CHE - CH..P	
TYPE	SIZE	i =	M.M.F.
CHPC	63	3	63B5
	71	3	71B5
	80	3	80B5

ORDER EXAMPLE

CHPC 71 CH 05 i= 108(3x36) M.M.F. 71

If the motor is also required, please specify:

Size es. 71 B4
 Power es. Kw 0.37
 Poles es. 4
 Voltage es. V230/400
 Frequency es. 50 Hz

2D and 3D drawings available on the web site www.chiaravalli.com
 Quantity, availability and prices with Chiaravalli B2B



CHPC/CH - PERFORMANCE WITH 4-POLE MOTORS 1400 REVS. INPUT

TYPE	i=ratio	n2 r/min	Kw=P1	Nm=T2
CHPC63 CH 04	105	13.3	0.12	42
	138	10.1	0.12	42
	180	7.8	0.12	46
	210	6.7	0.12	40
	300	4.7	0.12	36

TYPE	i=ratio	n2 r/min	Kw=P1	Nm=T2
CHPC71 CH 05	84	16.7	0.25	80
	108	12.9	0.25	90
	135	10.4	0.25	90

TYPE	i=ratio	n2 r/min	Kw=P1	Nm=T2
CHPC71 CH 07	120	11.7	0.55	280
	150	9.3	0.37	215
	180	7.8	0.37	235
	240	5.8	0.37	210
	300	4.7	0.25	275

TYPE	i=ratio	n2 r/min	Kw=P1	Nm=T2
CHPC71 CH 08	168	8.3	0.55	350
	192	7.3	0.37	280
	240	5.8	0.37	290
	300	4.7	0.37	275

TYPE	i=ratio	n2 r/min	Kw=P1	Nm=T2
CHPC63 CH 05	108	12.9	0.18	72
	135	10.4	0.18	85
	180	7.8	0.12	65
	210	6.7	0.12	67
	240	5.8	0.12	58
	300	4.7	0.12	56

TYPE	i=ratio	n2 r/min	Kw=P1	Nm=T2
CHPC71 CH 06	114	12.3	0.37	170
	135	10.4	0.37	176
	192	7.3	0.25	149
	240	5.8	0.25	130
	300	4.7	0.25	120

TYPE	i=ratio	n2 r/min	Kw=P1	Nm=T2
CHPC80 CH 07	90	15.6	0.75	310
	120	11.7	0.75	300
	150	9.3	0.55	260

TYPE	i=ratio	n2 r/min	Kw=P1	Nm=T2
CHPC80 CH 08	120	11.7	0.75	390
	138	10.1	0.75	360
	168	8.3	0.55	350
	192	7.3	0.55	330
	240	5.8	0.55	305

DIMENSIONS

CHPC.. /CH 06-07-08

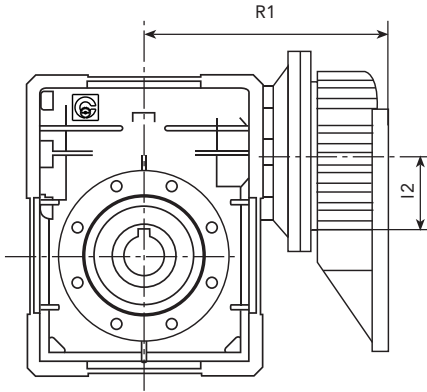

CHPC.. /CH 04-05

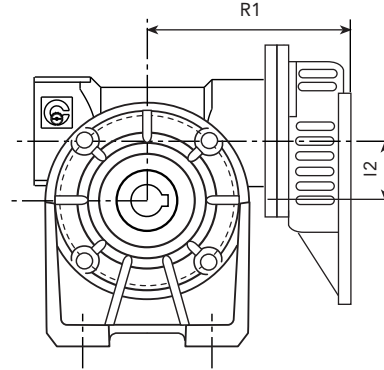

For other dimensions see pages 65 - 66 - 70 - 71 and 72 of the catalogue.

CHPC - CH	R1	I2
63 + 04	115	40
63 + 05	120	40
71 + 05	129	50
71 + 06	160	50
71 + 07	183	50
80 + 07	203	63
71 + 08	194	50
80 + 08	214	63

The choice of power installed is tied to the unification of the motors, therefore it is sometimes in exuberance compared to the gear; always verify the maximum torque indicated when making the selection and if in doubt please contact our technical office.

2D and 3D drawings available on the web site www.chiaravalli.com

Quantity, availability and prices with Chiaravalli B2B



CH - CH DOUBLE WORM GEAR

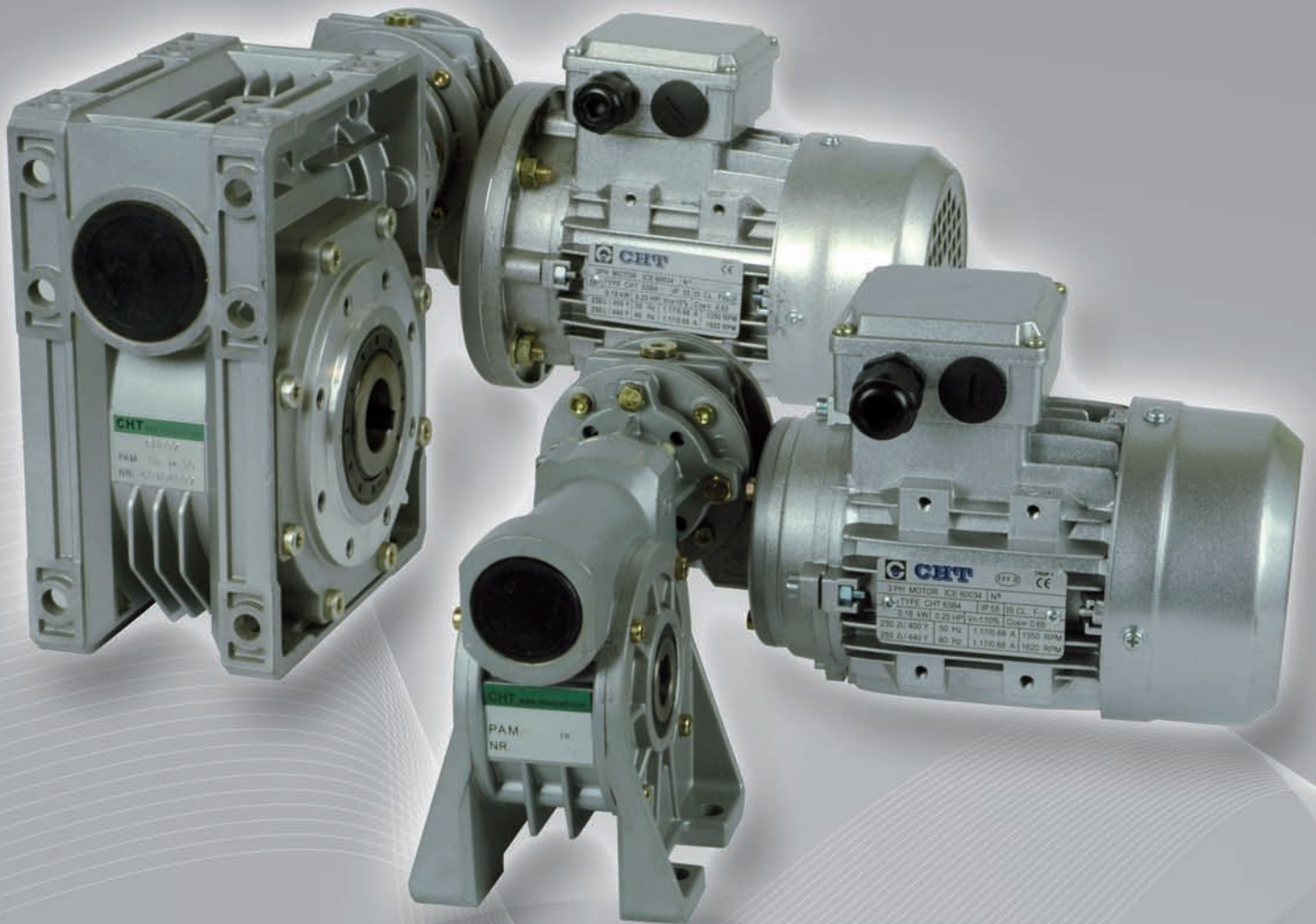



CH - CH DOUBLE WORM GEARS

DESIGNATION CH(R)/CH - CH(R)/CH..P

TYPE	SIZE	VERSION	FLANGE POS. (1)	i	EXEC.	M.M.F.
CH/CH	03/04	F	1	RATIO SEE PAGE 80	OAD	63B5
CH/CH..P	03/05	FA	2		OAS	63B14
CHR/CH		(2)			OBD	56B5
CHR/CH..P					OBS	56B14
					VAD	
					VAS	
					VBD	
					VBS	

TYPE	SIZE	VERSION	FLANGE POS. (1)	i	EXEC.	M.M.F.
CH/CH	03/06	FC	1	RATIO SEE PAGE 80	OAD	71B5
CH/CH..P	04/07	F	2		OAS	71B14
CHR/CH	04/08	(3)			OBD	63B5
CHR/CH..P					OBS	63B14
					VAD	56B5
					VAS	56B14
					VBD	
					VBS	

DIMENSIONS OF CH/CH COMBINED GEARS

78

CH 03/CH 04-05

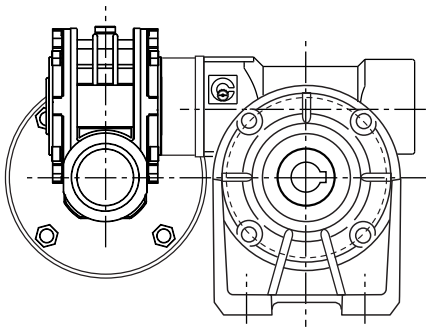

CH 03/CH 06

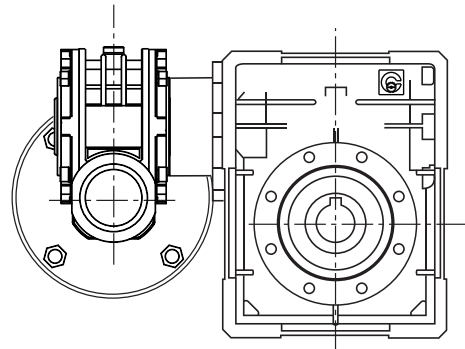

CH 04/CH 07-08

For the executions see the table with drawings on page 73, if not specified OBS would be supplied.



ORDER EXAMPLE

CH/CH	03/05P	FA	2	315	OBS	56B14
-------	--------	----	---	-----	-----	-------

If the motor is also required, please specify:

Size es. 56 C4
 Power es. Kw 0.09
 Poles es. 4
 Voltage es. V230/400
 Frequency es. 50 Hz
 Flange es. B14

- 1) see page 63 and 69
- 2) lack of instructions indicates that the gear is not equipped with an output flange. In this case the group can be fixed on feet CH/CH or be swinging CH/CH..P
- 3) lack of instructions indicates that the gear is not equipped with an output flange.



OAD

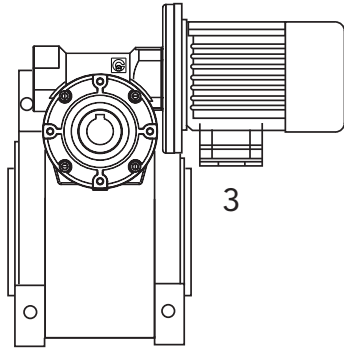

OAS

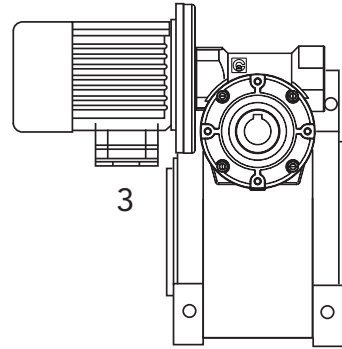

OBD

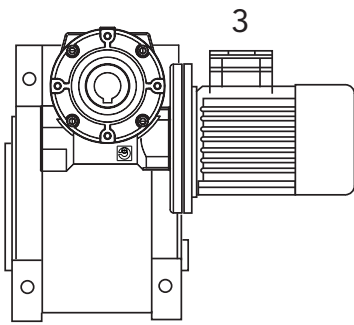

OBS

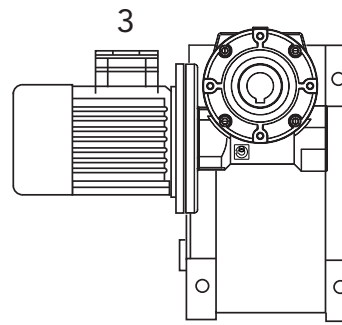

VAD

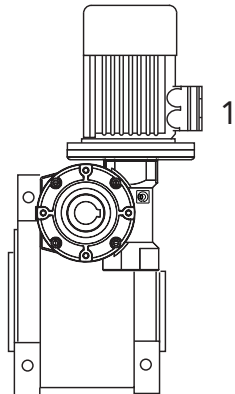

VAS

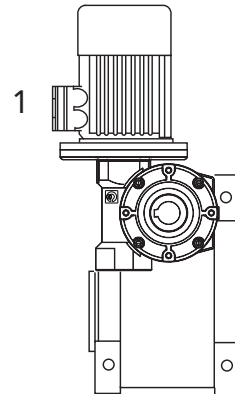

VBS

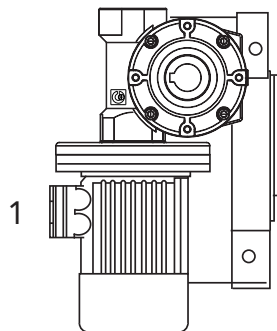

VBD

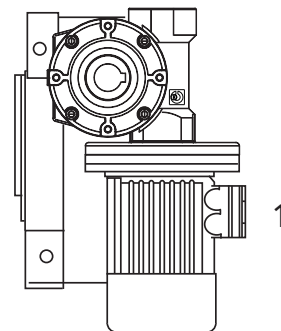

The execution determines the mounting position of the first gear in relation to the second gear. If not otherwise specified at the time of order, the group will be supplied in the OBS execution. The placing position refers to the second gear.



CH - CH PERFORMANCE WITH 4-POLE MOTORS 1400 REVS. INPUT

TYPE	i=ratio	n2 r/min	Kw=P1	Nm=T2
	245	5.7	0.09	58
	350	4.0	0.09*	58
	420	3.3	0.09*	58
CH	560	2.5	0.09*	58
03/04	700	2.0	0.09*	58
	840	1.7	0.09*	58
	1120	1.3	0.09*	58
	1680	0.8	0.09*	58
	2100	0.7	0.09*	58
	2760	0.5	0.09*	50

TYPE	i=ratio	n2 r/min	Kw=P1	Nm=T2
	240	5.8	0.12	77
	315	4.4	0.12	90
	420	3.3	0.09	90
CH	540	2.6	0.09	90
03/05	720	1.9	0.09*	90
	900	1.6	0.09*	90
	1120	1.3	0.09*	90
	1440	0.9	0.09*	90
	2160	0.6	0.09*	90
	2700	0.5	0.09*	90

TYPE	i=ratio	n2 r/min	Kw=P1	Nm=T2
	240	5.8	0.22	160
	315	4.4	0.22	180
	450	3.1	0.18	200
CH	570	2.5	0.12	180
03/06	720	1.9	0.12	200
	900	1.6	0.12	200
	1200	1.2	0.12	200
	1520	0.9	0.09*	200
	2280	0.6	0.09*	200
	2700	0.5	0.09*	200

TYPE	i=ratio	n2 r/min	Kw=P1	Nm=T2
	250	5.6	0.37	360
	300	4.7	0.37	360
	400	3.5	0.25	315
CH	525	2.7	0.25	360
04/07	700	2.0	0.18	360
	920	1.5	0.18	360
	1200	1.2	0.12	360
	1500	0.93	0.12*	360
	2100	0.67	0.12*	360
	2800	0.5	0.12*	360

TYPE	i=ratio	n2 r/min	Kw=P1	Nm=T2
	230	5.6	0.55	460
	300	4.7	0.55	490
	400	3.5	0.55	490
CH	525	2.7	0.37	490
04/08	700	2.0	0.37	490
	920	1.5	0.25	490
	1380	1.2	0.18	490
	1840	0.93	0.18	490
	2116	0.67	0.12	490
	2760	0.5	0.12	490

* The powers marked with an asterisk are higher than those that the gear allows, therefore the applicative choice must be made in accordance with the torque and not with the power.

DIMENSIONS OF CH/CH COMBINED GEARS

CH 03/CH 04-05

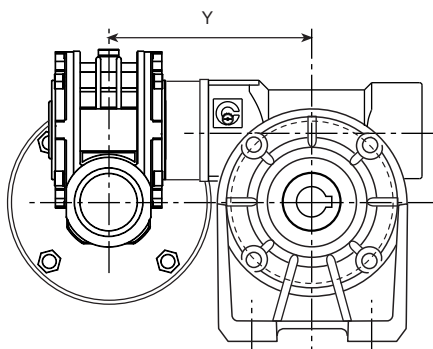

CH 03/CH 06

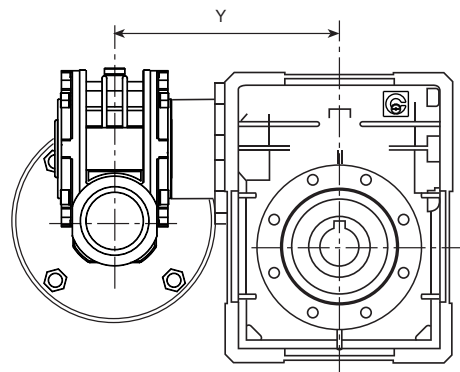

CH 04/CH 07-08

	Y
CH 03/04	120.5
CH 03/05	125.5
CH 03/06	165
CH 04/07	192
CH 04/08	204.5

For other dimensions see pages 65 - 66 - 70 - 71 and 72 of the catalogue.

The gear ratios are those most frequently requested. It is possible to obtain multiple combinations using the various ratios of the two single gears.

2D and 3D drawings available on the web site www.chiaravalli.com

Quantity, availability and prices with Chiaravalli B2B



TORQUE ARM

TYPE	I	A	B	Ø P	Ø C	Ø d	H	øE	S
CH 03	100	40	157.5	50	65	7	14	8	4
CH 04	100	40	157.5	50	65	7	14	8	4
CH 05	100	55	172.5	68	94	7	14	8	4
CH 06	150	52.5	232.5	75	90	9	20	10	6
CH 07	200	62.5	300	90	110	9	25	20	6
CH 08	200	75	312.5	110	130	11	25	20	6

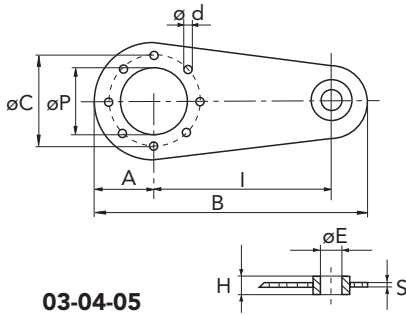

03-04-05

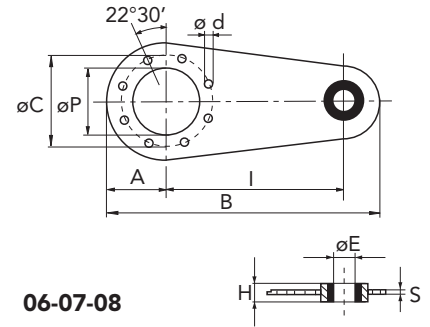
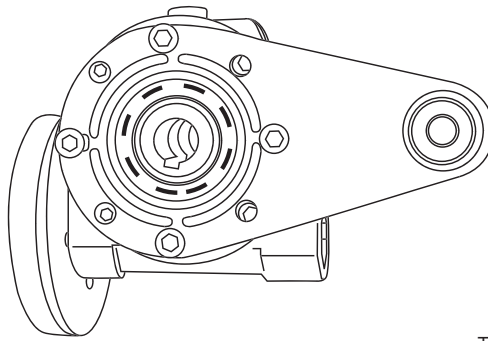

06-07-08

* Without anti vibration bush

The anchoring point of the torque arm is equipped with a vibration resistant bushing.



SINGLE OUTPUT SHAFT KIT

TYPE	A	Ø d	B	b	t1	T	L	d2	ød1
CH 03	30	14	35	5	16	61	96	M5x13	14
CH 04	40	18	45	6	20.5	70	115	M6x16	18
CH 05	60	25	65	8	28	89	154	M8x20	25
CH 06	60	25	65	8	28	127	192	M8x20	25
CH 07	60	30	65	8	33	134	199	M10x22	30
CH 08	60	35	65	10	38	149	214	M10x25	35

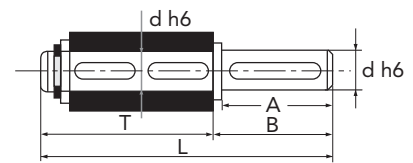
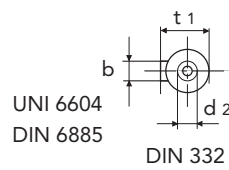

DOUBLE OUTPUT SHAFT KIT

TYPE	A	Ø d	B	R	b	t1	L	d2	ød1
CH 03	30	14	32.5	55	5	16	120	M5x13	14
CH 04	40	18	42.7	64	6	20.5	149.4	M6x16	18
CH 05	60	25	63.2	82	8	28	208.4	M8x20	25
CH 06	60	25	63.2	120	8	28	246.4	M8x20	25
CH 07	60	30	64	127	8	33	255	M10x22	30
CH 08	60	35	64	140	10	38	268	M10x25	35

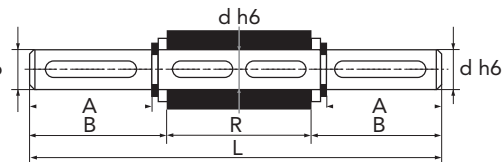
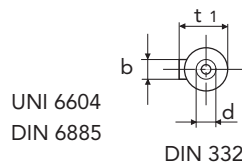



COVER

CH 03-04-05

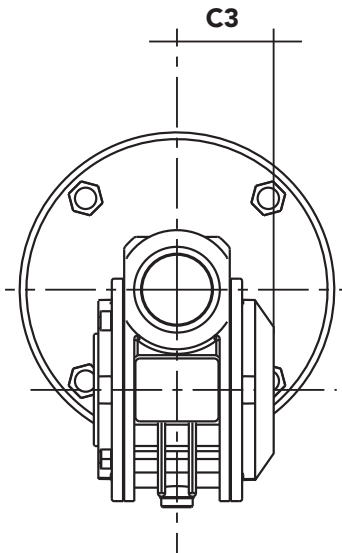

CH 06-07-08

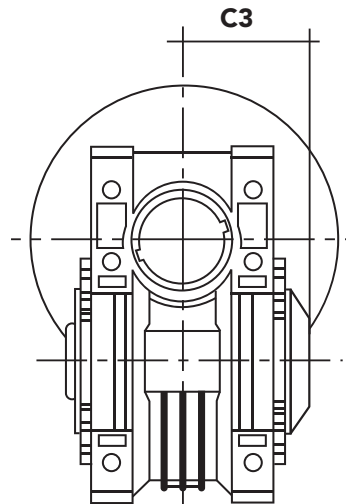

TYPE	C3
03	37
04	42
05	55
06	70
07	85,5
08	93,5



REDUCTION BUSHINGS KIT

SINGLE				
TYPE	$\sigma i / \sigma e$	L	tongues	Weight for kit kg
CHT BRM-S	9/11	20	4/3 x 4 x 11 RB*	0.006
CHT BRM-S	11/14	30	5/4 x 6 x 10 RB*	0.015
CHT BRM-S	14/19	40	6 x 5 x 30 *	0.045
CHT BRM-S	19/24	50	6 x 5.5 x 20 * 8 x 5.5 x 40 *	0.07
CHT BRM-S	24/28	60	8 x 9 x 40 *	0.08
CHT BRM-S	28/38	80	10 x 7 x 60 *	0.33
CHT BRM-S	38/42	110	12/10 x 10 x 48 RB*	0.22

DOUBLE				
TYPE	$\sigma i / \sigma e$	L	tongues	Weight for kit kg
CHT BRM-D	11/19	40	6 x 6 x 30 *	0.06
CHT BRM-D	14/24	50	8 x 7 x 40 A	0.12
CHT BRM-D	19/28	60	8 x 7 x 50 A	0.16
CHT BRM-D	24/38	80	10 x 8 x 60 A	0.44

* to drawing

Tongue acc. to UNI 6604 - DIN 6885
Quenched

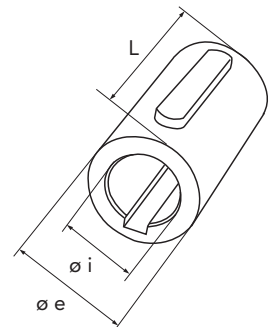
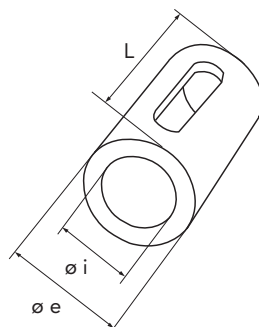

2D and 3D drawings available on the web site www.chiaravalli.com

Quantity, availability and prices with Chiaravalli B2B

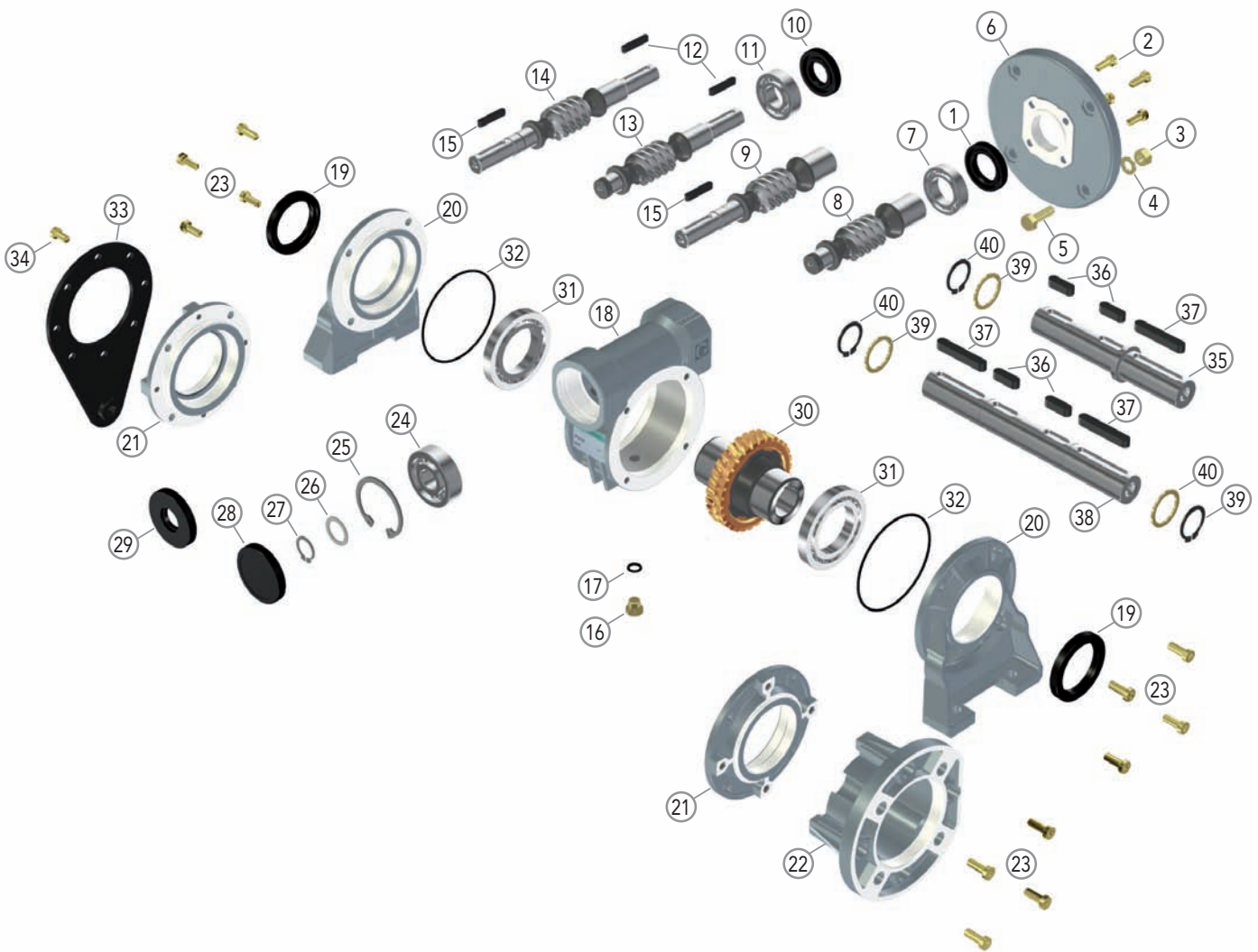

1	OIL SEAL	21	SIDE COVER
2	SCREW	22	OUTPUT FLANGE
3	NUT	23	SCREW
4	WASHER	24	BEARING
5	SCREW	25	SEEGER
6	MOTOR CONNECTION FLANGE	26	SPACER
7	BEARING	27	SEEGER
8	HOLE INPUT WORM	28	CAP
9	HOLE INPUT AND SHAFT OUTPUT WORM	29	OIL SEAL
10	OIL SEAL	30	WORM WHEEL
11	BEARING	31	BEARING
12	KEY	32	O-RING
13	SHAFT INPUT WORM	33	BRACCIO DI REAZIONE
14	DOUBLE EXTENDED INPUT SHAFT WORM	34	SCREW
15	KEY	35	SINGLE OUTPUT SHAFT
16	OIL PLUG	36	KEY
17	GASKET	37	KEY
18	CASING	38	DOUBLE OUTPUT SHAFT
19	OIL SEAL	39	SPACER
20	FOOT COVER	40	SEEGER

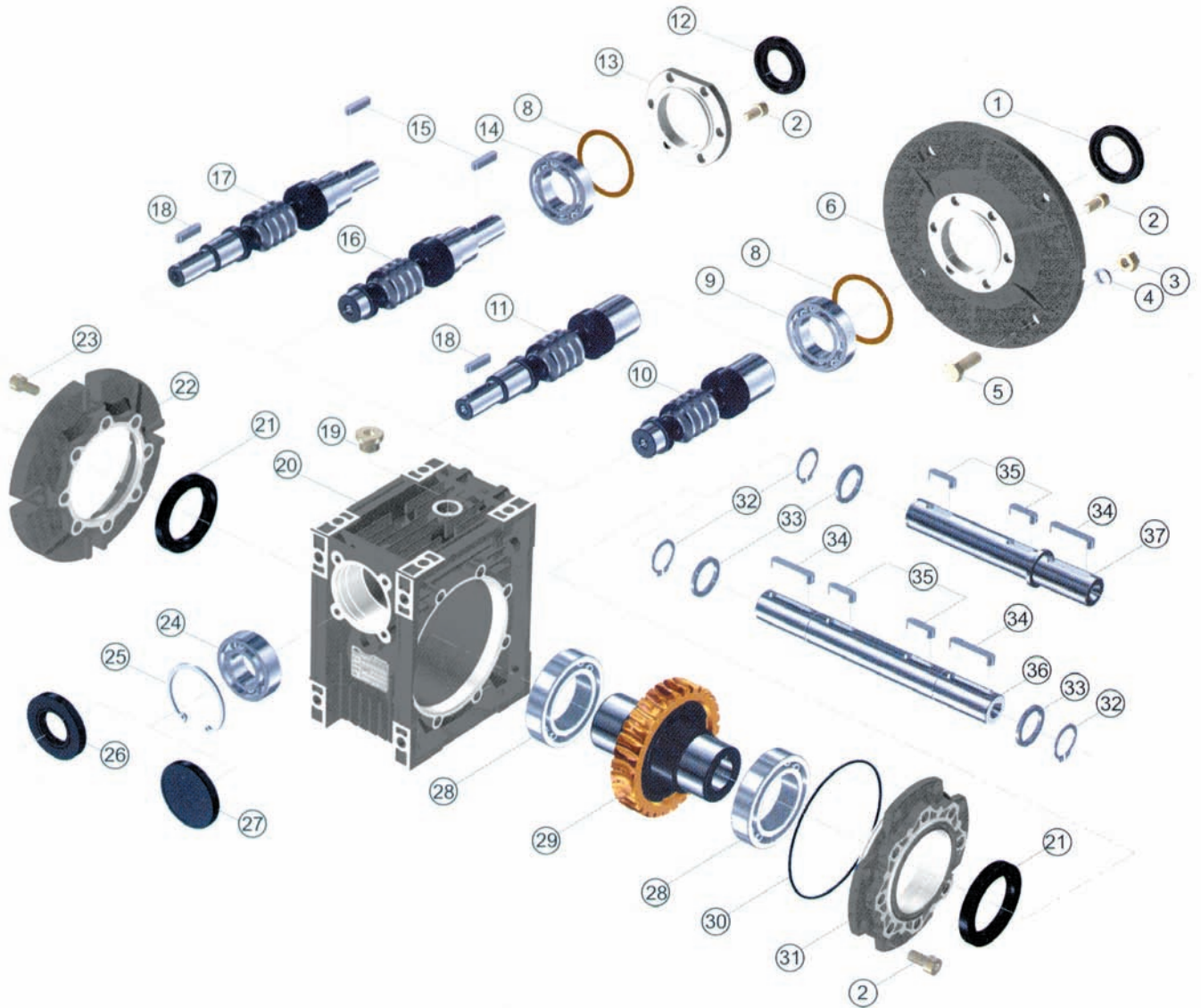

1	OIL SEAL	20	CASING
2	TORX SCREW	21	OIL SEAL
3	NUT	22	OUTPUT FLANGE
4	WASHER	23	EMBEDDED HEXAGONAL-HEAD SCREW
5	HEXAGONAL-HEAD SCREW	24	BEARING
6	MOTOR CONNECTION FLANGE	25	SEEGER
8	ADJUST SPACER	26	OIL SEAL
9	BEARING	27	CAP
10	HOLE INPUT WORM	28	BEARING
11	HOLE INPUT AND SHAFT OUTPUT WORM	29	WORM WHEEL
12	OIL SEAL	30	O-RING
13	INPUT COVER	31	OUTPUT COVER
14	BEARING	32	SEEGER
15	KEY	33	SPACER
16	SHAFT INPUT WORM	34	KEY
17	DOUBLE EXTENDED INPUT SHAFT WORM	35	KEY
18	KEY	36	DOUBLE OUTPUT SHAFT
19	OIL PLUG	37	SINGLE OUTPUT SHAFT



CH RADIAL LOADS ON THE OUTPUT SHAFT

The loads indicated are valid for all application directions.

The maximum allowable axial loads are equal to 1/5 of the radial load value shown in the table when applied with the same radial load; if this is not the case, please contact our technical office. If double output shafts are used, the sum of radial loads applicable to the centre lines of the two ends of the shaft must not exceed the value shown in the table below.

The radial loads related to the output speed (n2)=10 are the maximum loads supported by the gear.

- a | GEAR CONSTANT
- b | GEAR CONSTANT
- x | LOAD DISTANCE FROM SHAFT SHOULDER IN mm.
- F_{RX} | RADIAL LOAD IN POSITION X (IN N)
- F_R | RADIAL LOAD (N)
- F_A | AXIAL LOAD (N)

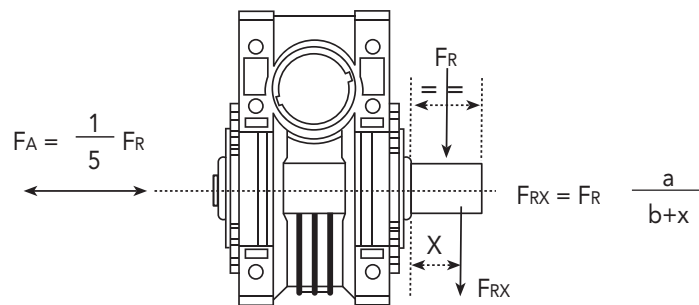

SIZES

Output speed	03	04	05	06	07	08
400	490	720	1000	1450	1800	2020
250	580	860	1190	1720	2140	2420
150	690	1010	1400	2020	2510	2840
100	790	1160	1600	2330	2880	3260
60	940	1380	1910	2770	3440	3880
40	1070	1570	2160	3130	3890	4380
25	1260	1850	2550	3700	4590	5180
10	1700	2500	3450	5000	6200	7000

CONSTANTS' VALUES

a	60	71	99	130	136	146
b	45	51	69	102	108	118

2D and 3D drawings available on the web site www.chiaravalli.com

Quantity, availability and prices with Chiaravalli B2B



RADIAL LOADS ON THE CENTRE LINE OF THE INPUT SHAFT

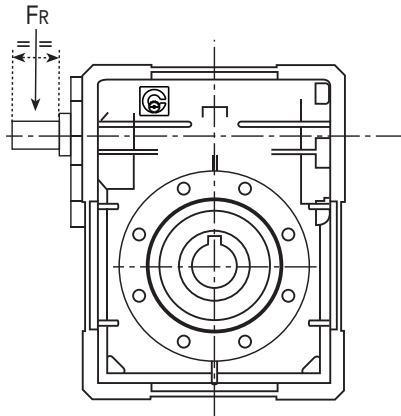

SIZES

	03	04	05	06	07	08
Fr max	100	150	220	700	975	1150

Notes: value of tables are in N



INSTALLATION

- The data shown on the identification name plate must correspond to the gear ordered.
- All the gears are supplied complete with permanent synthetic oil in a quantity that is sufficient for any assembly position.
- The gear must be fixed on a flat surface that is sufficiently rigid in order to avoid any vibration.
- The gear and the axis of the machine to be driven must be perfectly aligned.
- In the event that knocks, overloading or blockage of the machine are foreseen, the client must install a limiting device, joints, overload cut-out etc.
- Coupling with pinions, joints, pulleys and other parts must be done after the parts have been cleaned and knocks should be avoided whilst assembling as they could damage the bearings and other internal parts.
- In the event that the motor is supplied by the client, he must check that the flange and shaft tolerances correspond to a "normal" class; our motors satisfy this requirement.
- Check that the fixing screws for the gear and the related accessories are correctly tightened.
- Take suitable measures to protect the groups from any aggressive atmospheric agents.
- Where foreseen, protect rotating parts from any possible contact with the operators.
- If the gears are painted, protect the oil seals and the machined surfaces.
- All of the gears are painted RAL 9022 grey.

OPERATION AND RUNNING-IN

- To obtain the best performance the gears must first be run in by gradually increasing the power in the first few hours of operation, in this phase an increase in temperature is considered normal.
- In the event of defective operation, noise, oil leakage, etc. stop the gear immediately and, when possible, remove the cause. Alternatively, send the piece to our factory to be controlled.

MAINTENANCE

- The worm gears from size 03 to size 08 and the pre-stage modules are lubricated with permanent synthetic oil and therefore do not require any maintenance.

WAREHOUSE STORAGE

- If the warehouse storage will be for a long time, more than 3 months, the shafts and machined surfaces should be protected using antioxidants and the oil seals should be greased.

HANDLING

- Care must be taken not to damage the oil seals and the machined surfaces when handling the groups.

DISPOSAL OF PACKAGING

- The packaging in which our gears are delivered should be sent to specialised companies for recycling if possible.